

**ADCOM**<sup>®</sup>  
*details you can hear*

***GFP-710***

**Stereo Preamplifier**

**OWNER'S MANUAL**

## THE FOLLOWING PRECAUTIONS AND SAFETY INSTRUCTIONS ARE REQUIREMENTS OF UL AND CSA SAFETY REGULATIONS

**Warning:** To reduce the risk of fire or electric shock, do not expose this unit to rain or moisture.

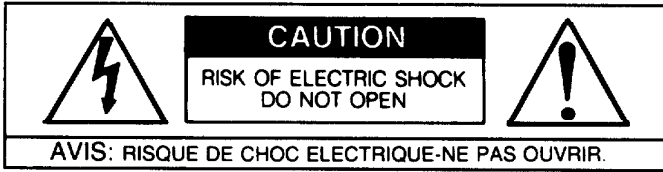

The graphic symbol of a lightning flash with an arrow point within a triangle signifies that there is dangerous voltage within the unit and it poses a hazard to anyone removing the cover to gain access to the interior of the unit. **Only qualified service personnel should make any such attempt.**



The graphic symbol of an exclamation point within an equilateral triangle warns a user of the device that it is necessary to refer to the instruction manual and its warnings for proper operation of the unit.



Do not place this unit on an unstable cart, stand, tripod, bracket, or table. The unit may fall, causing serious injury to a child or adult, and serious damage to the unit. Use only with a cart, stand, tripod, bracket, or table recommended by the manufacturer, or sold with the unit. Any mounting of the device should follow the manufacturer's instructions, and should use a mounting accessory recommended by the manufacturer.

Read all the safety and operating instructions before connecting or using this unit.

Retain this notice and the owner's manual for future reference.

All warnings on the unit and in its operating instructions should be adhered to.

All operating and use instructions should be followed.

Do not use this unit near water; for example, near a bathtub, washbowl, kitchen sink, laundry tub, in a wet basement, or near a swimming pool.

The unit should be installed so that its location or position does not interfere with its proper ventilation. For example, it should not be situated on a bed, sofa, rug, or similar surface that may block the ventilation openings; or placed in a built-in installation, such as bookcase or cabinet, that may impede the flow of air through its ventilation openings.

The unit should be situated away from heat sources such as radiators, heat registers, stoves, or other devices (including amplifiers) that produce heat.

The unit should be connected to a power-supply outlet only of the voltage and frequency marked on its rear panel.

The power-supply cord should be routed so that it is not likely to be walked on or pinched, especially near the plug, convenience receptacles, or where the cord exits from the unit.

Clean unit only as recommended in its instruction manual.

The power-supply cord of the unit should be unplugged from the wall outlet when it is to be unused for a long period of time.

Care should be taken so that objects do not fall, and liquids are not spilled, into the enclosure through any openings.

This unit should be serviced by qualified service personnel when:

- A. The power cord or the plug has been damaged; or
- B. Objects have fallen, or liquid has been spilled, into the unit; or
- C. The unit has been exposed to rain, or liquids of any kind; or
- D. The unit does not appear to operate normally, or exhibits a marked change in performance; or
- E. The device has been dropped, or the enclosure damaged.

**DO NOT ATTEMPT SERVICING OF THIS UNIT YOURSELF.  
REFER SERVICING TO QUALIFIED SERVICE PERSONNEL.**

### ATTENTION

POUR PRÉVENIR LES CHOCs ÉLECTRIQUES NE PAS UTILISER CETTE FICHE POLARISÉE AVEC UN PROLONGATEUR, UNE PRISE DE COURANT OU UNE AUTRE SORTIE DE COURANT, SAUF SI LES LAMES PEUVENT ÊTRE INSÉRÉES À FOND SANS EN LAISSER AUCUNE PARTIE À DÉCOUVERT.

### CAUTION

TO PREVENT ELECTRIC SHOCK DO NOT USE THIS POLARIZED PLUG WITH AN EXTENSION CORD, RECEPTACLE OR OTHER OUTLET UNLESS THE BLADES CAN BE FULLY INSERTED TO PREVENT BLADE EXPOSURE.

### CAUTION POWER LINES

Any outdoor antenna must be located away from all power lines.

### OUTDOOR ANTENNA GROUNDING

If an outside antenna is connected to your tuner or tuner-preamplifier, be sure the antenna system is grounded so as to provide some protection against voltage surges and built-up static charges. Section 810 of the National Electrical Code, ANSI/NFPA No. 70-1984, provides information with respect to proper grounding of the mast and supporting structure, grounding of the lead-in wire to an antenna discharge unit, size of grounding conductors, location of antenna discharge unit, connection to grounding electrodes, and requirements for the grounding electrode.

- a. Use No.10 AWG (5.3 mm<sup>2</sup>) copper, No.8 AWG (8.4 mm<sup>2</sup>) aluminum, No.17 AWG (1.0 mm<sup>2</sup>) copper-clad steel or bronze wire, or larger, as a ground wire.
- b. Secure antenna lead-in and ground wires to house with stand-off insulators spaced from 4-6 feet (1.22-1.83 m) apart.
- c. Mount antenna discharge unit as close as possible to where lead-in enters house.
- d. Use jumper wire not smaller than No.6 AWG (13.3 mm<sup>2</sup>) copper, or the equivalent, when a separate antenna-grounding electrode is used. See NEC Section 810-21 (j).

EXAMPLE OF ANTENNA GROUNDING AS PER NATIONAL ELECTRICAL CODE INSTRUCTIONS CONTAINED IN ARTICLE 810 - RADIO AND TELEVISION EQUIPMENT.

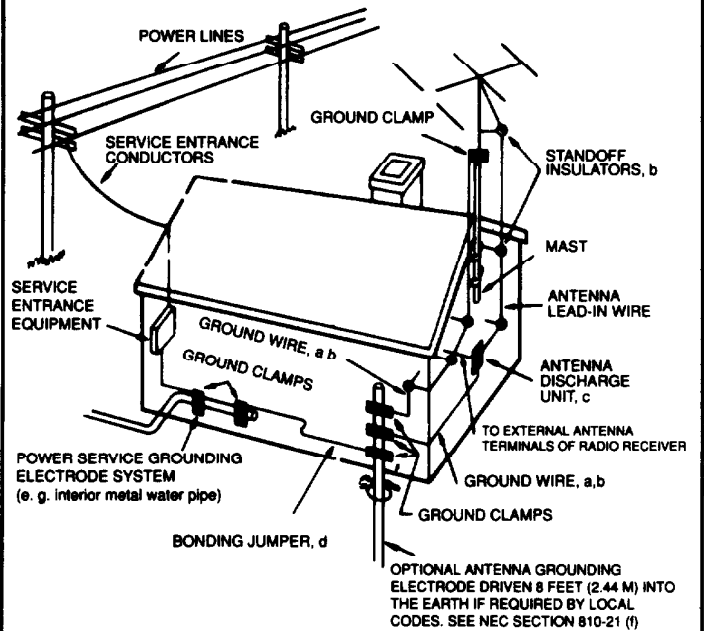

### NOTE TO CATV SYSTEM INSTALLER

This reminder is provided to call the CATV system installer's attention to Article 820-22 of the National Electrical Code that provides guidelines for proper grounding and, in particular, specifies that the cable ground shall be connected to the grounding system of the building, as close to the point of cable entry as practical.

## INTRODUCTION

Congratulations on your decision to purchase the GFP-710 preamplifier. The GFP-710 is the result of a thorough examination and re-evaluation of all factors affecting the sonic performance of preamplifiers. Careful selection of top quality components and circuit topologies ensure that you have made a wise choice that will reward you with exceptionally accurate and musical sound reproduction for years to come. To realize the full potential of your new amplifier, please read these operating and installation instructions thoroughly before making any connections.

## ADCOM PROTECTION PLAN (USA ONLY)

ADCOM offers the enclosed valuable Limited Warranty. Please read the details on the Warranty Card carefully to understand the extent of the protection offered by the Warranty, its reasonable limitations, and what you should do in order to obtain its benefits. Be sure to verify that the serial number printed on the rear panel matches the serial number on the outer carton.

If any number is altered or missing, you should notify us immediately in order to ensure that you have received a genuine ADCOM product which has not been opened, mishandled, or tampered with in any way. **Always retain your original sales receipt as a proof of purchase.**

## UNPACKING THE GFP-710

Before your new ADCOM preamplifier left our factory, it was carefully inspected for physical imperfections and tested for all electrical parameters as a routine part of ADCOM's systematic quality control. This, along with full operational and mechanical testing, should ensure a product flawless in both appearance and performance. After you have unpacked the GFP-710, inspect it for physical damage. Save the shipping carton and all packing material as they are intended to reduce the possibility of transportation damage, should the amplifier ever need to be shipped again. In the unlikely event damage has occurred, notify your dealer immediately and request the name of the carrier so a written claim to cover shipping damages can be initiated.

THE CARRIER CAN FORFEIT THE RIGHT TO A CLAIM AGAINST A PUBLIC CARRIER IF THE CARRIER IS NOT NOTIFIED PROMPTLY IN WRITING AND IF THE SHIPPING CARTON AND PACKING MATERIALS ARE NOT AVAILABLE FOR INSPECTION. SAVE ALL PACKING MATERIALS UNTIL THE CLAIM HAS BEEN SETTLED.

## PLACING THE GFP-710

Although the GFP-710 does not generate much heat it is good practice to ensure the amplifier's long-term, trouble-free operation to provide adequate ventilation for the unit. Therefore, the GFP-710 should be kept away from external sources of heat such as radiators and hot-air ducts.

We recommend that you exercise care when placing components on top of the GFP-710. If you are placing a heat producing component (as example, an amplifier) on top of or below the GFP-710, it is recommended that you allow at least 3 inches vertical spacing for proper airflow.

If your system includes the use of the phono input, you may find that placing components above or below the GFP-710 may induce hum, caused by the proximity of their power transformer to the phono cables or input jacks. If this should occur, moving the components will usually help reduce the hum.

If you observe these recommendations, the GFP-710 will perform reliably in any reasonable environment. You should also pay attention to such normal considerations as protection from excessive dust and moisture. Occasional vacuuming of accumulated dust on the chassis panels and around the ventilating slots should be all that is required.

The optimal performance of your new GFP-710 will ultimately depend on the care with which you make the connections between the amplifier, preamplifier and the loudspeakers. All input and output signal connections should be made only with high quality, low-loss, low capacitance cables. For recommendations of the type and quality of inter-connections that are best for your application consult with your ADCOM retailer.

## GFP-710 Rear Panel

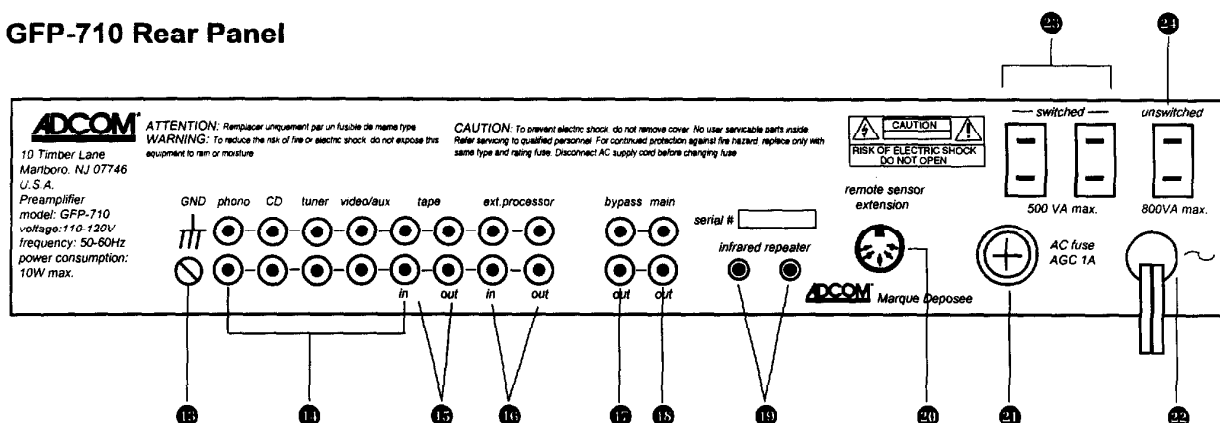

- 13 GND (Ground) To reduce the chance for hum connect the turntable ground lead to this attachment point.
- 14 Stereo Inputs Connect the various outputs from each signal source to these stereo inputs.
- 15 Tape IN / OUT Connect the Tape IN to the Play or Output connection of the tape deck. Connect Tape Out to the Record or Input jacks of the tape deck.
- 16 External Processor The processor in/out connectors allow for convenient connection of an external processor, like ADCOM's **GSA-700 surround** sound processor, or an equalizer. Consult the owner's manual for the external processor.
- 17 18 Stereo Outputs Main is a line level stereo output to be connected to the amplifier's inputs. Bypass means that the signal path does not include the tone control amplifiers, if you do not need tone controls. Both outputs can be used at the same time to accommodate a second amplifier for multi-room or multi-zone operation.
- 19 Infrared Repeater Output Connect the ADCOM IRA-500II infrared repeater to control other remote controlled equipment via the remote sensor extension.
- 20 Remote Control Sensor Input Connect either the ADCOM XR-500II or SPM-500II to extend the remote control capabilities of the GFP-710 via an external room or zone.
- 21 AC Fuse Always replace with the identical type and rating fuse for continued protection. See "Troubleshooting" for more information.
- 22 AC Cord Provides power to unit. The plug is a polarized type, for continued electrical safety observe proper polarization at mains outlet and do not modify plug in any way.
- 22 23 AC Convenience Outlets Electrical devices plugged into the Switched outlets will be provided with AC power when the GFP-710 is powered ON. Devices plugged into the Unswitched outlet will be always on. For continued electrical safety and to avoid damage to the GFP-710 DO NOT exceed the ratings printed on the rear panel. ADCOM does not recommend plugging power amplifiers into either switched or unswitched outlets on the preamplifier as they may exceed the maximum current available at the outlets.

### WARNING

**Whenever connections to or from the GFP-710 are being made, be certain that the AC On/Off Switch of the amplifier is in the OFF position, the AC Power Cord of the amplifier is disconnected from the AC wall outlet and that all associated components are turned off.**

## GFP-710 Front Panel

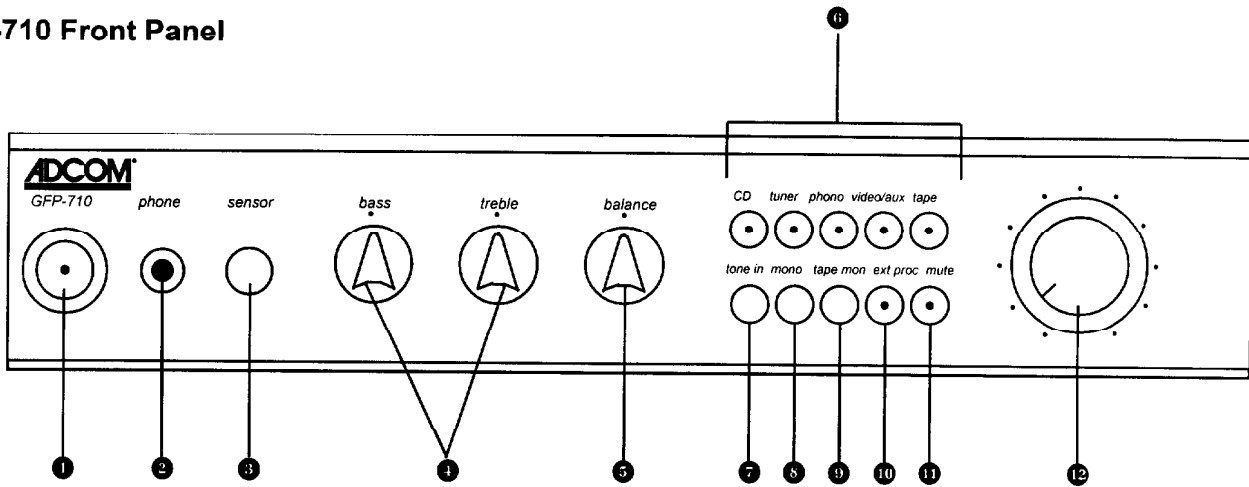

- 1 Power On/Off** The **GFP-710** is turned on by pressing either the remote control *power* button or toggling the front panel *power* switch. The LED in the middle of the *power* switch will glow red indicating the unit is on. When the unit is powered down (standby) the LED in the power switch will glow amber.
  - 2 Headphone Jack** Accomodates standard 1/4" stereo headphone plugs.
  - 3 Remote Control Sensor Lens** This lens protects the infrared receiver which receives commands from the remote control.  
 Note! The pathway between the lens and remote control must be free of obstructions for the remote control to operate the **GFP-710**.
  - 4 Bass and Treble controls** Emphasizes or reduces bass and treble frequencies.
  - 5 Balance Control** The **GFP-710** balance control feature provides finer balance adjustment allowing for greater balance accuracy and best stereo imaging.
  - 6 Input Source Selection** These five buttons select the source you desire for listening. When you select CD, tuner, phono or Video/aux, these signals are routed to the tape output for recording the selected source. Tape playback is accessed by press the Tape button. The presence of signal at the tape outputs can be confirmed by pressing the Tape Monitor button. The five source select buttons are also on the remote control.
  - 7 Tone in** Removes or engages tone control amplifier.
  - 8 Mono Switch** The mono setting combines both channels for a monaural input signal or where speaker placement does not accommodate stereo playback.
  - 9 Tape monitor** Confirms that signal is present at tape outputs. If a three head tape recorder is connected activating this circuit will allow direct monitoring from the recording. See tape recorder manual for details.
  - 10 Ext.Proc. (External Processor)** Selects an external audio processor, ie; surround sound or equalizer
  - 11 Mute** The **GFP-710's** mute feature is engaged by pressing the *mute* button on the remote control. This feature fully mutes the outputs. To deactivate the mute feature, press the *mute* button again or either of the two *volume* buttons on the remote control. (*Turning the front panel volume knob will not deactivate the mute feature*).
  - 12 Volume Control** The front panel control knob is motorized. It may be adjusted either by hand or by the *volume* buttons on the remote control. The *volume* knob's illuminated LED always indicates the present volume level. The *volume* control knob may be used to reduce the
- Remote Control** The supplied remote control duplicates the frequently used front panel controls such as ; Input Sources ● CD, tuner, tape, video/aux and phono, plus power ●, ext. proc.●, mute ●, and volume up/down ●.

## TROUBLESHOOTING

SYMPTOM	POSSIBLE REASON	POSSIBLE SOLUTION
Power LED ❶ does not glow. No sound.	AC Power Cord ❷ not plugged in AC Fuse failed	Plug in AC Power Cord ❷ Replace AC Fuse ❸
Power LED glows, but no sound.	Wrong source selected The external processor feature is activated ( <i>processor LED is on</i> ) without the external processor either being on or connected properly. Pre-amp or source unit is not on Connections in rear of amp are loose.	Make sure all components are on. Check for correct input. Switch external processor off. Verify all connections on rear of amp
One channel not producing sound.	Input ❹ ❺ ❻ or Output ❽ ❾ ❿ ⓫ connector(s) disconnected or loose Speaker disconnected	Verify both connections on that channel Verify connection at speaker
Hum from all speakers at any volume.	Ground loop (difference in ground voltages between components)	If cable TV is present (see Note 1) If cable TV is not present (see Note 2)
Hum from all speakers (hum goes up or down with volume control)	Problem with source unit (CD, tape, etc.), or RCA cable connecting that source unit to the pre-amp. Check Phono ground ❶.  Some major appliance, dimmer, halogen or fluorescent light is creating interference.	Try different source (tuner, tape, etc.) and/or different RCA cable  Make sure all appliances, dimmers, and suspect lights are off

**Note 1:** Cable TV systems can sometimes contribute to ground loop problems which cause "hum". To determine if your cable system is the contributing factor, disconnect the Cable-TV incoming signal line (round, 75W) at the wall, or the first component the cable is connected to (i.e. the cable box, or VCR). If the hum is no longer present, you must insert a "75W Ground Loop Isolator" before reconnecting the line. You should check with your Adcom Dealer to obtain one. If the "75W Ground Loop Isolator" works only partially or not at all, then please read Note 2 to complete the troubleshooting procedure.

**Note 2:** Make sure that the power amplifier is at least 6" from the Pre-amp and/or Processor. Usually putting another component between them is sufficient to minimize the hum. If this does not reduce the hum, turn the system off and disconnect all Inputs from the amplifier. If the hum still persists, then your Dealer or Service Center must examine the amplifier. If the hum disappears, try another set of RCA cables. Connect one RCA cable at a time to see if one specific cable is responsible. If any or all cables cause the hum to appear, then the pre-amp or processor should be evaluated for proper operation by your Dealer or Authorized Service Center.

## CARE AND MAINTENANCE

ADCOM has taken great care to produce a product that is flawless in appearance as well as performance. To maintain the chassis appearance, simply wipe clean the outer surface using a damp lint free cloth.

**DO NOT SPRAY OR POUR LIQUIDS OF ANY KIND ONTO THE GFP-710.**

## **SERVICING**

ADCOM's Technical Service Department will be happy to answer all questions pertaining to the installation and operation of your unit. In the unlikely event of difficulty, please contact us for prompt advice. If we cannot help you resolve the problem immediately, we may refer you to an authorized repair agency, or authorize the return of your unit to our plant.

All written inquiries should be addressed to:

**ADCOM Service Department  
10 Timber Lane  
Marlboro, NJ 07746 USA  
(732) 683-2356 Phone (732) 683-9790 Fax  
service@adcom.com**

Telephone inquiries are welcome from Monday through Friday between 9 AM and 4 PM, Eastern Standard Time. We will also be glad to answer any FAX or e-mail inquiries. Please include your phone and FAX numbers so we can respond.

When inquiring about your unit, please include the serial number, the name of the dealer from whom you purchased the unit, and the date of purchase.

If we ask you to return the unit to us for service, we will issue a specific Return Authorization number for your use.

**UNDER NO CIRCUMSTANCES SHOULD THE UNIT BE SHIPPED TO US WITHOUT PROPER AUTHORIZATION OR PACKED IN ANYTHING OTHER THAN ITS ORIGINAL PACKING.**

If the original packing has been lost, discarded or damaged, we will gladly supply replacement packaging at a nominal charge. Please mention your need when you contact us. Always ship PREPAID via UPS (United Parcel Service) or other appropriate carrier. FREIGHT COLLECT SHIPMENTS WILL BE REFUSED.

**DO NOT SHIP VIA PARCEL POST** as the packaging will not necessarily withstand the handling by our Postal Service.

## SPECIFICATIONS

<b>Output Impedance</b>	
Bypass / Main Outputs .....	100 Ohms
Tape Outputs .....	475 Ohms
<b>Output Level</b>	
Bypass / Main Outputs .....	2.0 Volts
<b>Output Level (Maximum)</b>	
Bypass / Main Outputs .....	10.0 Volts
<b>Frequency Response (+0.5 dB)</b>	
High Level .....	5Hz - 50kHz
Phono .....	5Hz - 50kHz
<b>THD + Noise (@ rated output 20Hz - 20kHz)</b>	
High Level .....	0.005%
Phono .....	0.005%
<b>Intermodulation Distortion (SMPTE @ rated output)</b>	
High Level .....	0.005%
Phono .....	0.005%
<b>Signal to Noise ( @ rated output - A weighted)</b>	
High Level .....	≥100dB
Phono .....	≥95dB
<b>Input Impedance</b>	
High Level .....	25KΩ
Phono .....	47kΩ
<b>Input Sensitivity (@ rated output)</b>	
High Level .....	205 mV
Phono .....	2.4mV
<b>RIAA accuracy (20Hz - 20kHz)</b>	
Phono .....	+/- 0.25dB
<b>Tone Controls</b>	
Bass (20 Hz) .....	+/- 11.5dB
Treble (20kHz) .....	+/- 8.5dB

## GENERAL SPECIFICATIONS

<b>Power</b> (available in 230V by special order) .....	115VAC-50/60Hz
<b>Power Consumption</b> .....	10 Watts max.
<b>Chassis Dimensions</b> .....	3" (76mm) x 17" (432mm) x 11 3/8" (289mm)
<b>Maximum Dimensions</b> .....	3 1/2" (89mm) x 17" (432mm) x 12 1/2"(318mm)
<b>Weight</b> .....	12 lbs (5.5kg)
<b>Weight, Packed</b> .....	15 lbs. (6.8kg)



10 Timber Lane  
Marlboro, New Jersey 07746  
USA  
Voice: 732.683.2356  
Fax: 732.683.9790  
[www.adcom.com](http://www.adcom.com)